

MULTITOP
Antriebsanschluss:
 DIN 3337 / ISO 5211

Baulänge:
 DIN 3202 – F1
 EN 558-1 - Reihe 1

Flansche:
 DIN 2501 – PN 10 - PN 40
 ASME B16.5 – Class 150

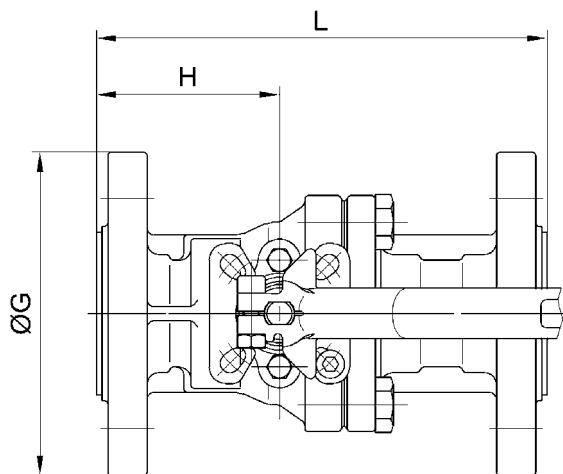

MULTITOP
Mounting plate:
 DIN 3337 / ISO 5211

Face to face dimension:
 DIN 3202 – F1
 EN 558-1 - line 1

Flanges:
 DIN 2501 - PN 10 – PN 40
 ASME B16.5 – Class 150

DN	NPS	A	ØB		ØC	ØD		E	F	ØG	H	L	kg
			PN10-40	Class150		PN10-40	Class150						
15	1/2"	160	65	60,5	17	4x14	4x15,7	53	102	95	58	130	2,5
20	3/4"	160	75	69,9	20	4x14	4x15,7	56	104	105	65	150	3,3
25	1"	175	85	79,2	25	4x14	4x15,7	67	120	115	65	160	4,2
32	1 1/4"	175	100	88,9	32	4x18	4x15,7	72	125	140	75	180	5,7
40	1 1/2"	220	110	98,6	40	4x18	4x15,7	83	140	150	85	200	7,3
50	2"	220	125	120,7	50	4x18	4x19,1	91	147	165	100	230	10,0

Gewicht inklusive Handhebel / Weight including hand lever